

**ALFA  
ROMEO**

# CATALOGO RAPIDO PER L'ORDINAZIONE DI RICAMBI ORIGINALI

giugno 1974

Publicazione n. 2235  
con varianti per  
Giulia Super 1,3/1,6

GIULIA-1750-2000  
TUTTE LE VERSIONI

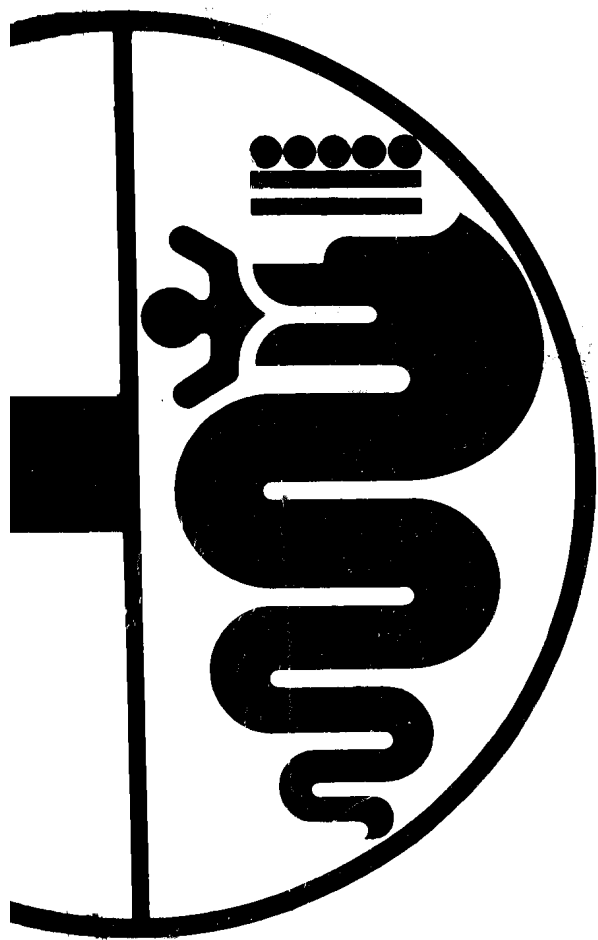

**ALFA  
ROMEO**

**CATALOGO RAPIDO RICAMBI  
CATALOGUE RAPID PIÈCES DÉTACHÉES  
SHORT SPARE PARTS CATALOG  
SCHNELL ERSATZTEILCATALOG**

## PREMESSA

In questo fascicolo sono raffigurate ed elencate tutte le parti di ricambio essenziali o di maggior uso e consumo occorrenti in caso di riparazione o revisione alle parti MECCANICHE, ELETTRICHE e di CARROZZERIA delle vetture Alfa Romeo 1300-1600-1750-2000.  
Ad ogni ricambio corrisponde un numero categorico composto da 14 cifre divise in gruppi.  
Ogni gruppo ha un preciso significato per cui bisogna sempre rispettare nella scritturazione non solo le cifre, ma anche i raggruppamenti:

<b>105</b>	<b>00</b>	<b>01</b>	<b>010</b>	<b>07</b>	<b>00</b>
GIULIA	BERLINA	GRUPPO DEL BASAMENTO	BASAMENTO	ESPONENTE DI MODIFICA	

Alle parti di ricambio che nel tempo subiscono variazioni, vengono assegnati nuovi numeri categorici. In questo caso il Concessionario ALFA ROMEO, alla richiesta di una parte di ricambio che ha subito variazioni, fornisce il pezzo di nuova introduzione che annulla e sostituisce il precedente.

## INTRODUCTION

Dans ce catalogue sont illustrées et énumérées toutes les pièces détachées, essentielles ou les plus employées, nécessaires soit à la réparation soit à la révision des organes mécaniques, de l'équipement électrique et de la carrosserie des nos voitures Alfa Romeo 1300-1600-1750-2000.  
A' chaque pièce détachée correspond un numéro de catalogue qui est composé par une série de 14 chiffres divisés en groupes.  
Chaque groupe a une importance spécifique, c'est pourquoi on doit respecter toujours dans la transcription non seulement les chiffres mais aussi les regroupements:

<b>105</b>	<b>00</b>	<b>01</b>	<b>010</b>	<b>07</b>	<b>00</b>
GIULIA	BERLINA	ENSEMBLE CARTER MOTEUR	CARTER MOTEUR	NUMERO DE MODIFICATION	

Aux pièces détachées qui peuvent-avoir-été changés entretemps, nous donnons des repères nouveaux. En ce cas le concessionnaire Alfa Romeo, au lieu de la pièce détachée commandée et qui a été changée, va vous fournir la pièce de nouvelle production qui annule et remplace la précédente.

## INTRODUCTION

On this pamphlet you can find: the drawings and the list of all the spare parts both of first importance and fast moving you may require to repair or to overhaul: the mechanical units, the electrical units and the body components on our Alfa Romeo 1300-1600-1750-2000 cars.  
To each item corresponds a catalogue number consisting of fourteen figures divided into several groups.  
Each group has its specific meaning so that you must always respect in writing not only the figures but even their subdivisions:

<b>105</b>	<b>00</b>	<b>01</b>	<b>010</b>	<b>07</b>	<b>00</b>
GIULIA	BERLINA	ENGINE BLOCK ASSY	ENGINE BLOCK	MODIFICATION FIGURE	

New catalogue numbers are specified for the changed spare parts. In this case our distributor has to supply the new item as replacement of the cancelled spare part requested by you.

## VERWORT

In dieser Broschüre sind alle Teile abgebildet und aufgeführt, die bei Reparatur und Überholungsarbeiten wesentlich benötigt werden, was Mechanik, Elektrik und Karosserie des Fahrzeuges Alfa Romeo 1300-1600-1750-2000 anbetrifft.  
Zu jedem Ersatzteil gehört eine Ersatzteilnummer, die aus 14 Ziffern, in Gruppen aufgeteilt, besteht.  
Jede Gruppe hat eine besondere Bedeutung, so dass man bei der Schreibung nicht nur die Ziffern, sondern auch die Gruppierung beachten muss:

<b>105</b>	<b>00</b>	<b>01</b>	<b>010</b>	<b>07</b>	<b>00</b>
GIULIA	BERLINA	GRUPPE KURBELGEHÄUSE	KURBELGEHÄUSE	ÄNDERUNGS-EXPONENT	

Den Ersatzteilen, die mit der Zeit Änderungen erfahren, neue Teilnummern werden gegeben. Bei Anforderung eines Teiles, der eine Änderung erfahren hat, liefert der Alfa Romeo - Händler den neuen Teil der den vorangegangenen annulliert und ersetzt.

**Indice delle tavole**, la tavola corrispondente all'organo o all'elemento di organo al quale si può riferirsi.

dans le **répertoire des planches** la planche correspondante à l'organe ou l'élément d'organe dont la pièce peut se rattacher.

in the **index**, find the plate corresponding to the sub-assembly to which this part may be attached.

im **Tafelverzeichnis**, die Nummer der Bildtafel suchen, der das Teil oder Aggregat gehört.

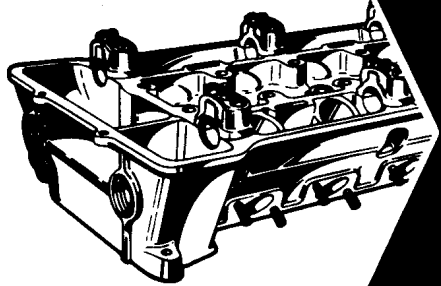

**INDICE DELLE TAVOLE**  
**REPertoire DES PLANCHES**  
**INDEX OF TABLES**  
**TAFELVERZEICHNIS**

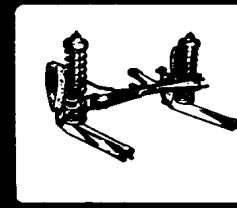
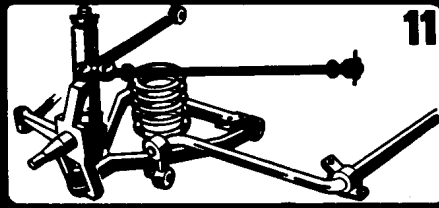
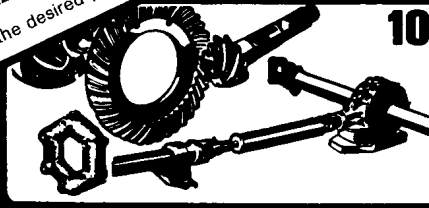
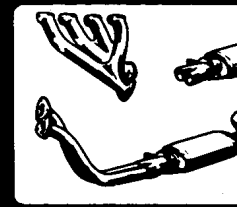
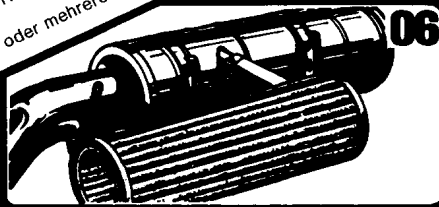
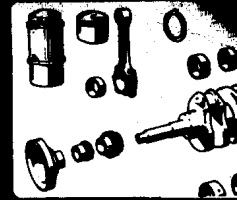
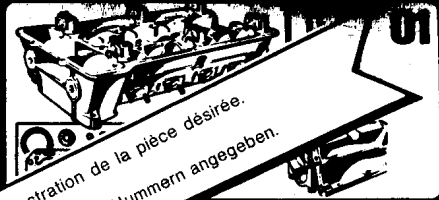

**DEL CATALOGO-UTILISATION**  
**GEBRAUCHSANWEISUNG**

Determinata la tavola, cercare l'illustrazione del pezzo desiderato. - La planche étant déterminée, rechercher l'illustration de la pièce désirée.  
 Having found the plate, look for the illustration of the desired part. - Für das Teil ist - auf der Bildtafel - eine oder mehrere Nummern angegeben.

**TAVOLA 01**

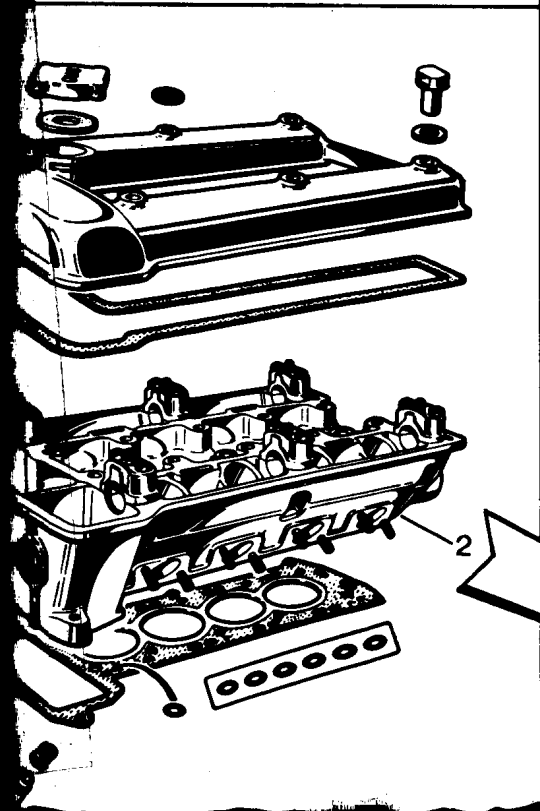

**INCASTELLATURA MOTORE**

Figura	Denominazione Description Benennung	Notes Notice Hinweise	N. d'Ordinazione N. de pièces Catalog No Bestell.-Nr.	Quantità	1300				1600				1750				2000			
2	Testa cilindri		105.36.01.053.00																	

Tipo di vettura interessato,  
 Type de la voiture en question  
 Model of the car in question,  
 Interessierte Fahrzeug.

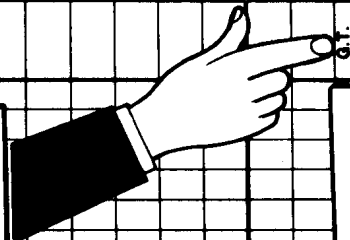

g. r. JUNIOR 1.8

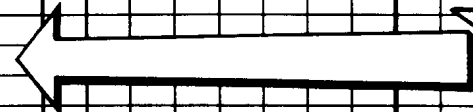
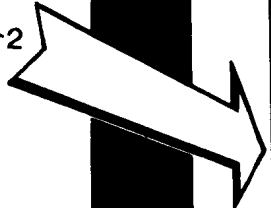



Il manuale a cui questo file è allegato è stato convertito in formato digitale partendo dal “**catalogo rapido per l’ordinazione di ricambi originali**”, in italiano, francese, inglese e tedesco pubblicato dall’Alfa Romeo durante il mese di Giugno 1974.

Le vetture interessate sono **Giulia – 1750 – 2000 in tutte le versioni**, con una aggiunta, posizionata in fondo (pagina 254) per **Giulia Super 1300 e 1600**.

Nelle prime pagine sono riportati i dati di applicazione, il numero di stampato e la validità. Il manuale in formato **PDF** richiede l’uso di “**acrobat reader**”.

E’ strutturato in modo da permettere la ricerca in base al capitolo sia direttamente dall’indice, cliccando sul capitolo di interesse, sia dal menù “segnalibri” (bookmarker) a sinistra.

Il menù segnalibri va aperto cliccando sulla parola “segnalibri” (oppure bookmaker) sul lato sinistro della finestra di lavoro.

All’inizio di ogni capitolo è possibile tornare alla pagina di indice cliccando su “**INDICE DELLE TAVOLE**” nella barra segnalibri a sinistra.

Quando sotto al puntatore del mouse è presente un link verso un’altra parte del manuale la manina di Acrobat diventa una mano con l’indice puntato.

Ogni pagina del manuale è in realtà una immagine, è possibile stamparla (anche singolarmente), ma non effettuare ricerche con parole chiave.



INDICE DELLE TAVOLE  
REPERTOIRE DES PLANCHES  
INDEX OF TABLES  
TAFELVERZEICHNIS

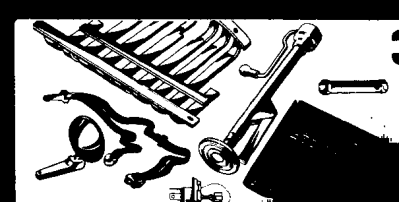
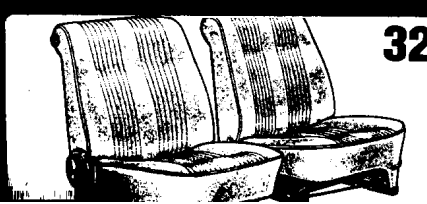
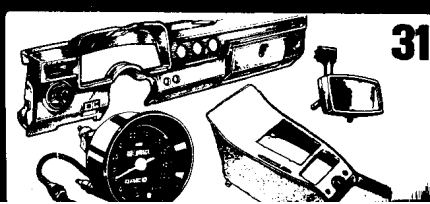
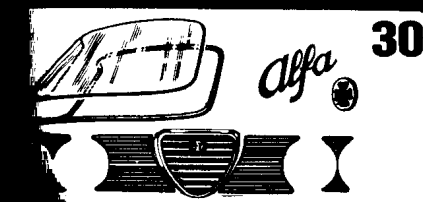
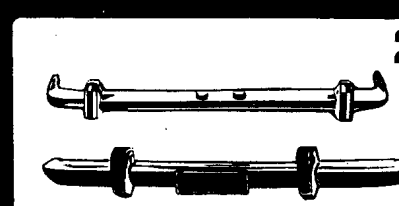
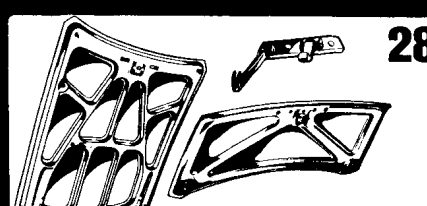
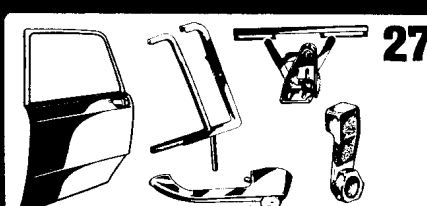
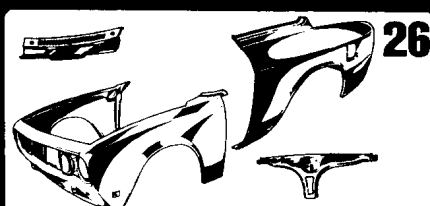
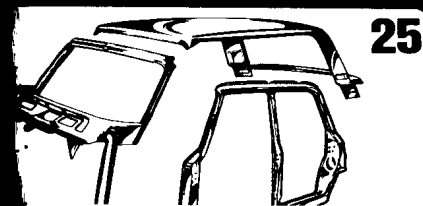
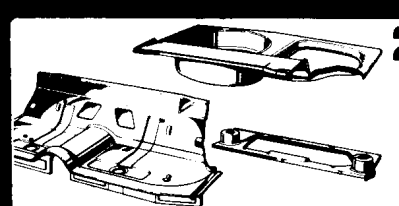
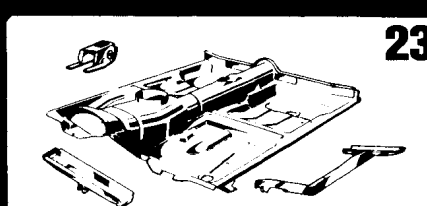
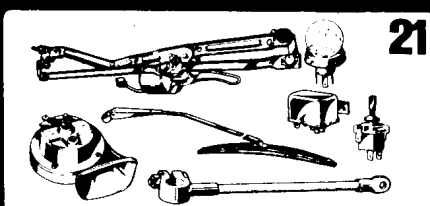
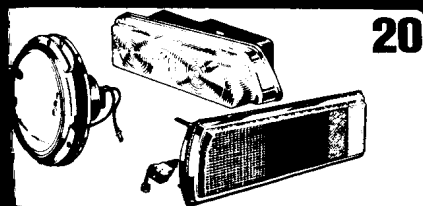
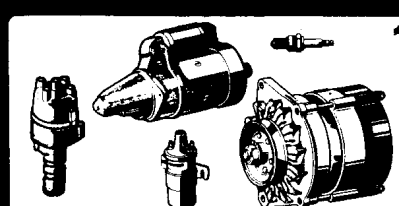
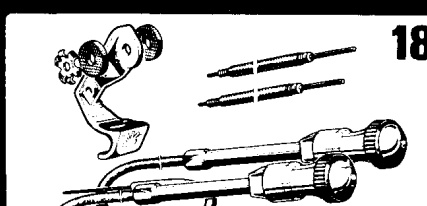
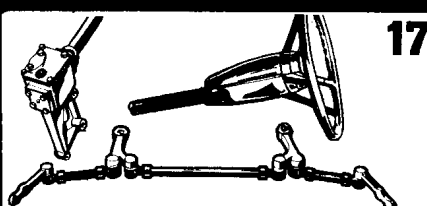
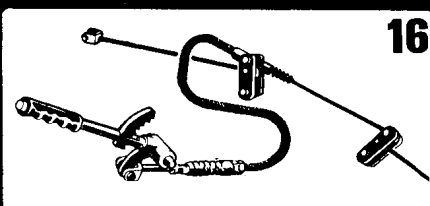
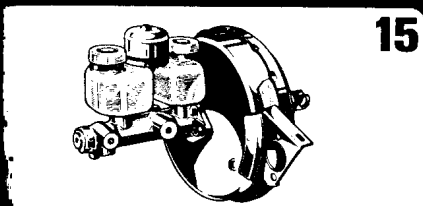
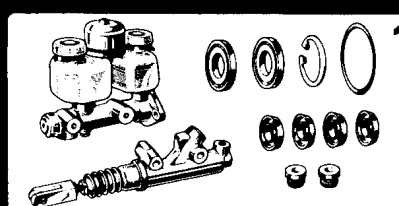
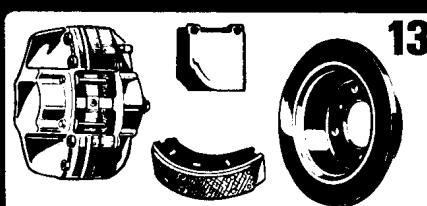
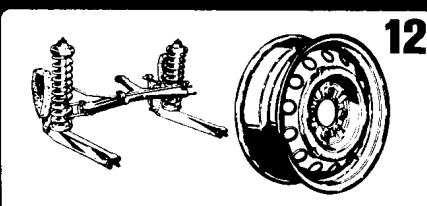
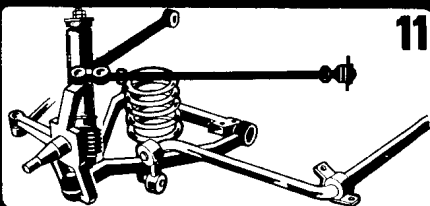
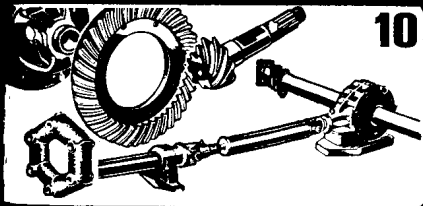
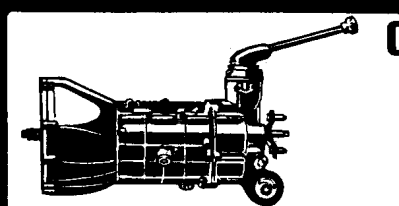
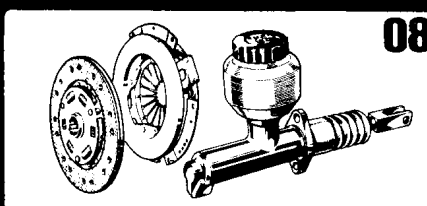
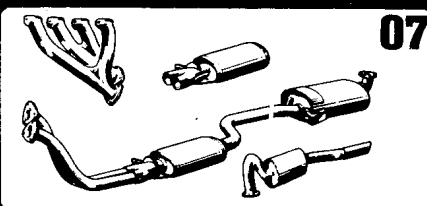
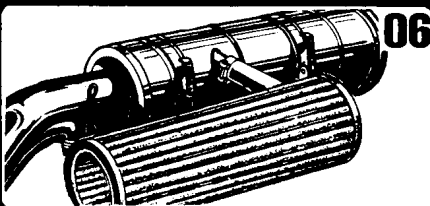
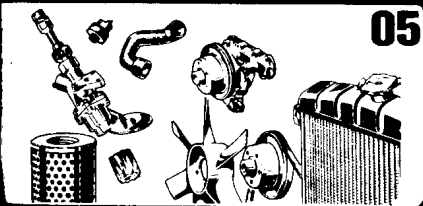
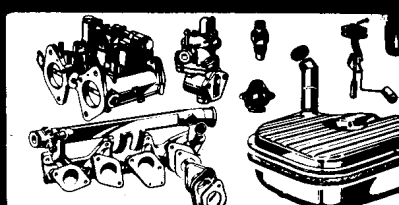
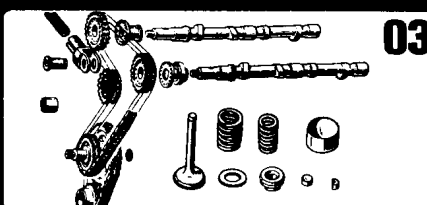
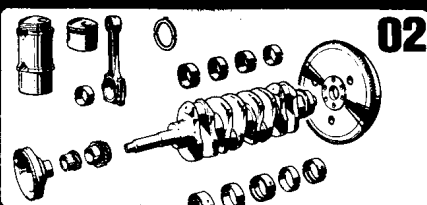
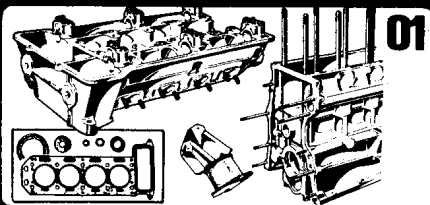



GRUPPI MECCANICI  
ORGANES MECANIKUES  
MECHANICAL UNITS  
MECHANISCHE AGGREGATE

GRUPPI ELETTRICI  
ENSEMBLES ELECTRIQUES  
ELECTRICAL UNITS  
ELEKTRISCHE APPARATE

CARROZZERIA  
CARROSSERIE  
BODY PARTS  
KAROSSERIE

**LE ORDINAZIONI DOVRANNO ESSERE CORREDATE DAI SEGUENTI DATI:**

- Il numero di categorico del particolare richiesto (da rilevarsi sul presente fascicolo o sui cataloghi generali).
- In mancanza di precise indicazioni dell'esatto numero di categorico, è opportuno procedere ad una accurata denominazione del particolare e segnalare il tipo di veicolo ed i numeri dell'auto-telaio e del motore.
- Indirizzo esatto per la destinazione del materiale.
- Indicazione dei documenti necessari.
- Mezzo di spedizione prescelto.

**LES COMMANDES DEVRONT ETRE FOURNIES DES DONNEES SUIVANTES:**

- Le numero de reference de la pièce demandée (a relever sur le present fascicule ou sur les catalogues generaux).
- A défaut d'indications precises de l'exactitude de la reference il est opportun d'indiquer une denomination tres precise de la piece, signaler le type de vehicule, les numeros du chassis et du moteur.
- Adresse exacte pour la destination du materiel.
- Indication des documents necessaires.
- Moyen de transport choisi.

**ORDERS SHOULD BE ACCOMPANIED BY THE FOLLOWING INFORMATION:**

- The code number of the part required (to be found on this leaflet or on general parts catalogues).
- When no exact code number is given, you must name the part accurately and state the type of vehicle and chassis and engine numbers.
- Exact address of where the material is to be sent.
- Indication of documents needed.
- Method of despatch preferred.

**DIE BESTELLUNGEN SOLLTEN FOLGENDE DATEN ENTHALTEN:**

- Die Ersatzteilenummern des verlangten Ersatzteils (diese finden Sie im Ersatzteilkatalog oder im Schnellkatalog).
- Sollte eine Teilenummer nicht genau angegeben werden können, empfiehlt es sich eine geeignete Bezeichnung des abgebildeten Ersatzteils sowie den Fahrzeugtyp, Fahrgestell und Motornummer anzuführen.
- Genaue Adresse des Wareneempfängers.
- Angabe aller notwendigen Dokumente.
- Gewünschte Versandart.



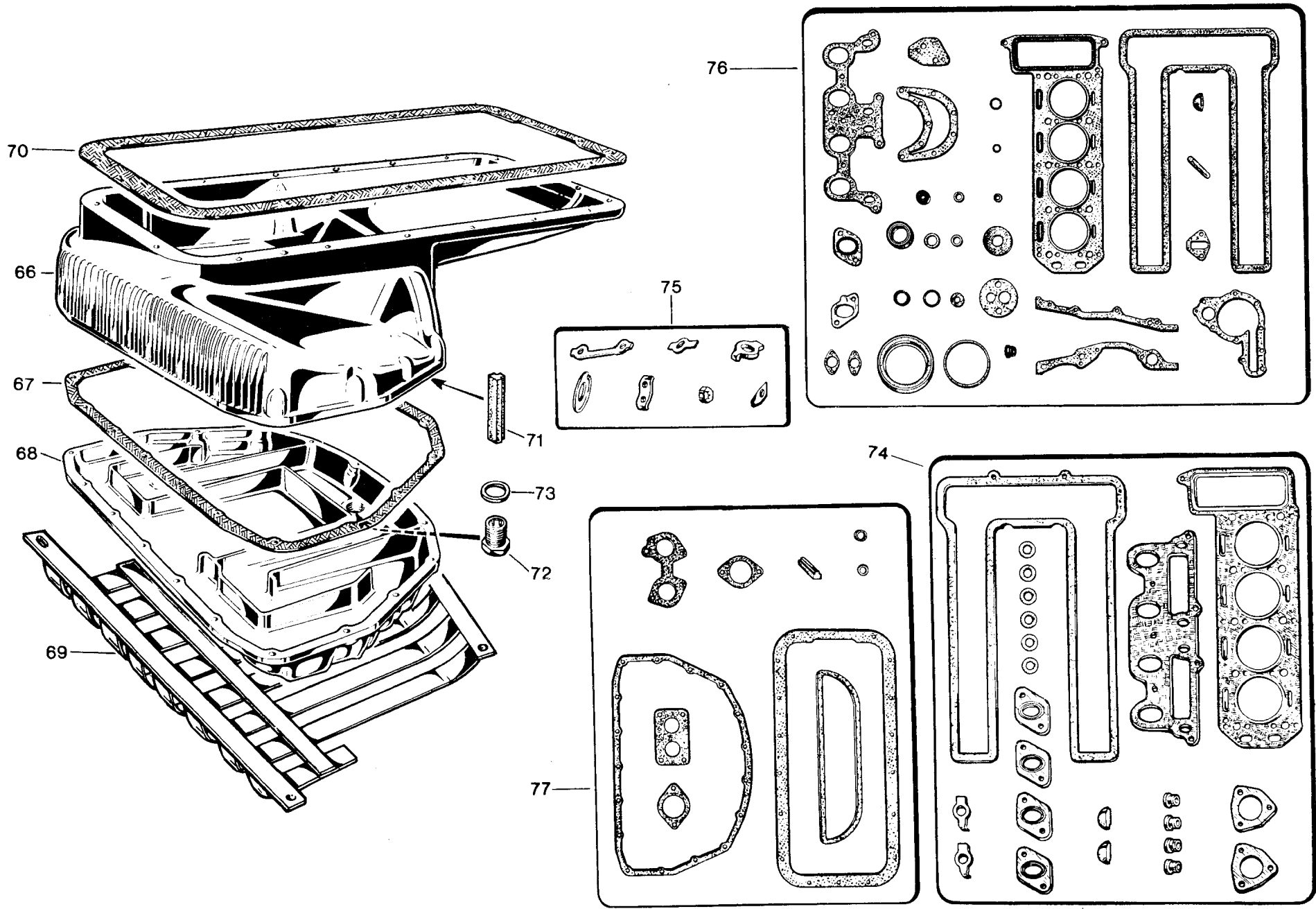



# INCASTELLATURA MOTORE

Figura	Denominazione Description Benennung	Notes Notice Hinweise	N. d'Ordinazione N. de pièces Catalog No Bestell.-Nr.	Quantità	1300				1600				1750		2000					
					GIULIA T.I.	GIULIA SUPER	GIULIA SUPER 1,3	G.T. JUNIOR	G.T. JUNIOR 1,3	SPIDER JUNIOR	SPIDER JUNIOR 1,3	GIULIA SUPER	GIULIA SUPER 1,6	G.T. JUNIOR	SPIDER JUNIOR 1,6	BERLINA	G.T.V.	SPIDER V.	BERLINA	G.T.V.
1	Basamento	A	105.00.01.010.05	1																
			105.06.01.010.05	1	●			●		●										
			105.00.01.010.07	1									17							
			105.85.01.010.01	1									18							
			105.06.01.010.07	1	3			7		11										
			105.39.01.010.03	1	4	●		8		12										
			115.09.01.010.01	1			●		●		●									
			115.03.01.010.01	1								●	●	●						
			105.41.01.010.01	1											●	●	●			
			105.12.01.010.01	1														●	●	●
2	Testa cilindri		105.30.01.053.00	1	●	●	●	●	●	●	●									
			101.21.01.053.01	1									15							
			105.36.01.053.00	1									16	●	●	●				
			105.41.01.053.00	1												21	23	25		
			105.48.01.053.03	1												22	24	26		
			105.12.01.053.00	1														●	●	●
3	Coperchio	B	105.00.01.031.01	1								●								
			105.14.01.031.01	1									●							
			105.06.01.031.01	1	●			●		●										
		C	115.09.01.031.01	1		●														
			116.01.01.031.02	1			●		●		●									
			116.00.01.031.01	1								●	●	●						
			105.48.01.031.01	1										●	●	●				
116.08.01.031.01	1													●	●	●				
4	Coperchio	A	105.00.01.510.02	1	●							●								
			105.02.01.510.00	1									●							
	D	105.14.01.510.00	1	●																
		105.02.01.510.01	1				●		●											
	E	105.46.01.510.00	1				●		●		●		●	●	●					
		105.14.01.510.02	1	●	●	●	●	●	●	●	●	●	●	●	●	●	●	●		

Notes - Notice - Hinweise

FRANÇAIS

A Sans trou de aérateur  
 B Pour moteurs avec dynamo  
 C Pour moteur avec alternateur  
 D Avec trou de aérateur  
 E Avec trous de fixation avant  
 F Pour voitures avec filter à droite

ENGLISH

A Without breather  
 B For engine with dynamo  
 C For engine with alternator  
 D With breather  
 E With-holes for front fixing  
 F For R.H filter cars

DEUTSCH

A Ohne Locher Entlüftung  
 B Für Motoren mit Lichtmaschine  
 C Für Motoren mit Drehstromgenerator  
 D Mit Locher Entlüftung  
 E Mit vordere Befestigungslocher  
 F Für Fahrzeuge mit rechtsseitigem Filter

N° al telaio N° de châssis Fahrgestell no.	3 → 1.029.000	8 → 1.230.001	13 → 1.840.000	18 → 880.001	23 → 1.375.000	28 → 1.410.280	33 → 645.001 ↔ 1.029.000	38 → 1.410.280 ↔ 1.820.000
	4 → 1.029.001	9 → 1.260.000	14 → 1.840.001	19 → 1.875.000	24 → 1.375.001	29 → 1.411.245	34 → 1.211.001 ↔ 1.230.000	39 → 1.411.246 ↔ 1.411.859
	5 → 1.211.000	10 → 1.260.001	15 → 862.000	20 → 1.875.001	25 → 1.820.000	30 → 1.411.246	35 → 862.001 ↔ 880.000	40 → 1.411.860 ↔ 1.820.000
1 → 645.000	6 → 1.211.001	11 → 1.671.500	16 → 862.001	21 → 1.740.000	26 → 1.820.001	31 → 1.361.250	36 → 1.230.001 ↔ 1.260.000	
2 → 345.001	7 → 1.230.000	12 → 1.671.501	17 → 880.000	22 → 1.740.001	27 → 1.410.279	32 → 1.361.251	37 → 1.211.001 ↔ 1.260.000	





Figura	Denominazione Description Benennung	Notes Notice Hinweise	N. d'Ordinazione N. de pièces Catalog No Bestell.-Nr.	Quantità	1300				1600				1750		2000						
					GIULIA T.I.	GIULIA SUPER	GIULIA SUPER 1.3	G.T. JUNIOR	G.T. JUNIOR 1.3	SPIDER JUNIOR	SPIDER JUNIOR 1.3	GIULIA SUPER	GIULIA SUPER 1.6	G.T. JUNIOR 1.6	SPIDER JUNIOR 1.6	BERLINA	G.T.V.	SPIDER V.	BERLINA	G.T.V.	SPIDER V.
5	Supp. albero motore anteriore		105.00.01.104.00	1	●	●	●	●	●	●	●	●	●	●	●	●	●	●	●		
6	Supp. albero motore intermedio		105.00.01.105.00	2	●	●	●	●	●	●	●	●	●	●	●	●	●	●	●		
7	Supp. albero motore centrale		105.00.01.106.01	1	●	●	●	●	●	●	●	●	●	●	●	●	●	●	●		
8	Supporto albero motore posteriore	non rinforzato	A	101.10.01.107.00	1	●															
			B	105.00.01.107.02	1	●			●		●										
		rinforzato		105.41.01.107.00	1		●	●		●		●		●	●						
			105.12.01.107.00	1												●	●	●			
9	Supporto motore	◆	105.02.01.080.01	1	●	●	●	●	●	●				●	●		●	●	●		
		◆	105.14.01.081.03	1	●	●	●	●	●	●				●	●		●	●	●		
		◆	105.57.01.080.00	1															●	●	
		◆	105.57.01.081.01	1															●	●	
10	Guida valvola scarico		101.10.01.503.02	4	●	●	●	●	●	●	●	●	●	●	●	●	●	●	●		
11	Serie guida valvola aspiraz.		105.00.01.503.04/01	1	●	●	●	●	●	●	●	●	●	●	●	●	●	●	●		
12	Cappello		1315.12093	6	●	●	●	●	●	●	●	●	●	●	●	●	●	●	●		
13	Cavallotto		105.41.01.867.00	1	●	●	●	●	●	●	●	●	●	●	●	●	●	●	●		
14	Sede valvola scarico	C		101.00.01.505.03	4	●	●	●	●	●	●	●									
				101.10.01.505.01	4													●	●	●	
				105.12.01.505.01	4														●	●	●
15	Sede valvola aspirazione	D		105.39.01.504.01	4	●	●	●	●	●	●	●	15								
				105.00.01.504.01	4									16	●	●	●				
				105.36.01.504.01	4																
				105.48.01.504.01	4																
				105.12.01.504.01	4															●	●
16	Piastra posteriore		105.00.01.143.00	1	①							15									
			105.41.01.143.00	1	②							16									
			105.12.01.143.00	1		●	●	●	●	●	●	●	18	●	●	●	●	●	●	●	
17	Piastra		105.12.05.312.00	1		●	●	●	●	●	●	●	●	●	●	●	●	●	●		
18	Coperchio posteriore		1315.10019	1	●	●	●	●	●	●	●	●	●	●	●	●	●	●	●		
19	Boccola		101.10.01.115.00	1	●	●	●	●	●	●	●	●	●	●	●	●					
			116.08.01.115.00	1													●	●	●		

Notes - Notice - Hinweise	
FRANÇAIS	
<b>A</b>	Pas armé
<b>B</b>	Armé
<b>C</b>	Echappement
<b>D</b>	Admission
ENGLISH	
<b>A</b>	Standard
<b>B</b>	Heavy Duty
<b>C</b>	Exhaust
<b>D</b>	Intake
DEUTSCH	
<b>A</b>	Normal
<b>B</b>	Hochleistung
<b>C</b>	Auslass
<b>D</b>	Einlass

N° autotelaio N° de châssis Fahrgestell no.	③ → 1.029.000	⑧ → 1.230.001	⑬ → 1.840.000	⑱ → 880.001	⑳ → 1.375.000	㉔ → 1.410.280	㉘ → 645.001 ↔ 1.029.000
	④ → 1.029.001	⑨ → 1.260.000	⑭ → 1.840.001	⑲ → 1.875.000	㉑ → 1.375.001	㉙ → 1.411.245	㉚ → 1.211.001 ↔ 1.230.000
	⑤ → 1.211.000	⑩ → 1.260.001	⑮ → 862.000	⑳ → 1.875.001	㉒ → 1.820.000	㉚ → 1.411.246	㉛ → 862.001 ↔ 880.000
① → 645.000	⑥ → 1.211.001	⑪ → 1.671.500	⑯ → 862.001	㉑ → 1.740.000	㉓ → 1.820.001	㉜ → 1.361.250	㉞ → 1.230.001 ↔ 1.260.000
② → 645.001	⑦ → 1.230.000	⑫ → 1.671.501	⑰ → 880.000	㉒ → 1.740.001	㉔ → 1.410.279	㉝ → 1.361.251	㉟ → 1.211.001 ↔ 1.260.000

③⑧ → 1.410.280 ↔ 1.820.000
③⑨ → 1.411.246 ↔ 1.411.859
④⑩ → 1.411.860 ↔ 1.820.000

*Alfa Romeo*



# INCASTELLATURA MOTORE

Figura	Denominazione Description Benennung	Notes Notice Hinweise	N. d'Ordinazione N. de pièces Catalog No Bestell.-Nr.	Quantità	1300				1600				1750		2000					
					GIULIA T.I.	GIULIA SUPER	GIULIA SUPER 1,3	G.T. JUNIOR	G.T. JUNIOR 1,3	SPIDER JUNIOR	SPIDER JUNIOR 1,3	GIULIA SUPER	GIULIA SUPER 1,6	G.T. JUNIOR 1,6	SPIDER JUNIOR 1,6	BERLINA	G.T.V.	SPIDER V.	BERLINA	G.T.V.
20	Boccola		105.00.01.313.00	1	●	●	●	●	●	●	●	●	●	●	●	●	●	●	●	
21	Prolunga	A	lungh. mm. 120 105.00.01.316.00	1	●			●		●				●	●	●				
			lungh. mm. 160 105.48.01.316.00	1		●		●		●				●	●	●				
			116.08.01.316.00	1			●		●		●									
			116.00.01.316.00	1								●	●	●					●	●
22	Astina indic. livello olio	A	lungh. mm. 445 105.00.01.040.00	1	●		●	●	●	●	●	●	●	●	●	●	●	●	●	
			lungh. mm. 495 105.48.01.040.00	1		●		●		●				●	●	●		●	●	●
23	Raccordo		116.00.06.353.01	1			●		●			●	●	●		●	●	●		
24	Rubinetto		2360.32461	1	●	●	●	●	●	●	●	●	●	●	●	●	●	●	●	
25	Tappo conico anteriore		2360.31618	2	●	●	●	●	●	●	●	●	●	●	●	●	●	●	●	
26	Tappo conico posteriore		2360.31619	2	●	●	●	●	●	●	●	●	●	●	●	●	●	●	●	
27	Tappo		105.00.01.568.00	5	●	●	●	●	●	●	●	●	●	●	●	●	●	●	●	
28	Tappo		105.36.01.563.00	1		●	●	●	●	●	●	●	●	●	●	●	●	●	●	
29	Tappo		2360.31504	1																
30	Tappo		105.48.01.652.00	1		●	●	●	●	●	●	●	●	●	●	●	●	●	●	
31	Tappo olio		1315.12801	1	●	●	●	●	●	●	●	●	●	●	●	●	●	●	●	
32	Boccola		101.10.01.112.00	10	●	●	●	●	●	●	●	●	●	●	●	●	●	●	●	
33	Boccola		1315.12023	12	●	●	●	●	●	●	●	●	●	●	●	●	●	●	●	
34	Dado fiss. testa		1315.12022	10	●	●	●	●	●	●	●	●	●							
			105.41.01.506.00	10										●	●	●	●	●	●	
35	Rondella fiss. testa		101.00.01.539.00	8	●	●	●	●	●	●	●	●	●							
			105.41.01.539.00	8										●	●	●	●	●	●	
36	Rondella fiss. testa-cavallotto		101.00.01.541.00	2	●	●	●	●	●	●	●	●	●							
			105.41.01.541.00	2										●	●	●	●	●	●	
37	Pomello	B	con esagono incass. 101.00.01.133.00	6	●			●		●				●	●	●				
		C	con fresat. esterna 105.48.01.133.01	6		●	●		●	●	●							●	●	●
38	Trasmettitore di pressione	Bosch	105.48.06.323.00	1													●	●	●	
		Borletti	105.48.06.323.02	1	●	●	●	●	●	●	●	●	●	●	●	●	●	●	●	●
39	Trasmettitore di pressione	Borletti	105.00.06.323.02	1	●	●	●	●	●	●	●	●	●	●	●	●	●	●	●	

Notes - Notice - Hinweise

FRANÇAIS

A Longueur en mm.  
 B Avec exagone encastré  
 C Avec fraisage extérieur

ENGLISH

A Long in mm.  
 B Socket head knob  
 C Knurled knob

DEUTSCH

A Lang mm.  
 B Innensechskant  
 C Rändelschraube

N° autotelaio	3 → 1.029.000	8 → 1.230.001	13 → 1.840.000	18 → 880.001	23 → 1.375.000	28 → 1.410.280	33 → 645.001 ↔ 1.029.000	38 → 1.410.280 ↔ 1.820.000
N° de châssis	4 → 1.029.001	9 → 1.260.000	14 → 1.840.001	19 → 1.875.000	24 → 1.375.001	29 → 1.411.245	34 → 1.211.001 ↔ 1.230.000	39 → 1.411.246 ↔ 1.411.859
Fahrgestell no.	5 → 1.211.000	10 → 1.260.001	15 → 862.000	20 → 1.875.001	25 → 1.820.000	30 → 1.411.246	35 → 862.001 ↔ 880.000	40 → 1.411.860 ↔ 1.820.000
	1 → 645.000	11 → 1.671.500	16 → 862.001	21 → 1.740.000	26 → 1.820.001	31 → 1.361.250	36 → 1.230.001 ↔ 1.260.000	
	2 → 645.001	12 → 1.671.501	17 → 880.000	22 → 1.740.001	27 → 1.410.279	32 → 1.361.251	37 → 1.211.001 ↔ 1.260.000	





Figura	Denominazione Description Benennung	Notes Notice Hinweise	N. d'Ordinazione N. de pièces Catalog No Bestell.-Nr.	Quantità	1300				1600				1750		2000					
					GIULIA T.I.	GIULIA SUPER	GIULIA SUPER 1,3	G.T. JUNIOR	G.T. JUNIOR 1,3	SPIDER JUNIOR	SPIDER JUNIOR 1,3	GIULIA SUPER	GIULIA SUPER 1,6	G.T. JUNIOR 1,6	SPIDER JUNIOR 1,6	BERLINA	G.T.V.	SPIDER V.	BERLINA	G.T.V.
40	Rondella		1315.10116	8	●	●	●	●	●	●	●	●	●	●	●	●	●	●	●	
41	Dado		101.00.01.135.00	10	●	●	●	●	●	●	●	●	●	●	●	●	●	●	●	
42	Palmutter		2120.20249	8	●	●	●	●	●	●	●	●	●	●	●	●	●	●	●	
			2120.92315	8												●	●	●	●	
43	Piastrina	per supp. non rinf.	A 105.00.01.161.00	1	●															
		per supp. rinf.	B 105.00.01.161.01	2	●	●	●	●	●	●	●	●	●	●	●	●	●	●	●	●
44	Prigioniero fiss. testa		101.00.01.103.01	10	●	●	●	●	●	●	●	●	●	●	●	●	●	●	●	
			105.00.01.103.00	10																
			105.41.01.103.01	10										●	●	●	●	●	●	
45	Guarnizione tappo olio		1315.12411	1	●	●	●	●	●	●	●	●	●	●	●	●	●	●	●	
46	Anello tenuta anteriore		105.00.01.176.00	1	●	●	●	●	●	●	●	●	●	●	●	●	●	●	●	
47	Anello tenuta posteriore		—																	
			105.64.01.177.00	1	●	●	●	●	●	●	●	●	●	●	●	●	●	●	●	●
48	Guarnizione testa con anellini		101.00.01.508.07/01	1	●	●	●	●	●	●	●	●	●	●	●	●	●	●	●	
			105.00.01.508.03/01	1																
			105.48.01.508.00/01	1											●	●	●	●	●	
			105.12.01.508.00/01	1														●	●	●
49	Anellino di tenuta		2340.35006	6	●	●	●	●	●	●	●	●	●	●	●	●	●	●	●	
50	Guarniz. coperchio	senza fori fiss. ant.	C 105.00.01.507.02	1	●			●												
		con fori fiss. ant.	D 105.14.01.507.01	1	●	●	●	●	●	●	●	●	●	●	●	●	●	●	●	●
51	Guarnizioni coperchio lato aspirazione		E 105.00.01.304.02	1																
			E 105.06.01.304.00	1	●	●	●	●	●	●	●	●	●	●	●	●	●	●	●	●
			105.41.01.304.00	1											●	●	●	●	●	●
52	Guarnizioni coperchio lato scarico		F 105.00.01.303.02	1																
			F 105.06.01.303.00	1	●	●		●		●										
			F 105.41.01.303.00	1											●	●	●	●	●	●
			F 116.08.01.303.00	1														●	●	●
			F 116.00.01.303.00	1																
	F 116.01.01.303.00	1			●		●		●											
53	Guarnizione		1315.12408	2	●	●	●	●	●	●	●	●	●	●	●	●	●	●	●	

Notes - Notice - Hinweise

FRANÇAIS

A Pour support pas armé  
 B Pour support armé  
 C Sans trous de fixation avant  
 D Avec trous de fixation avant  
 E Côté admission  
 F Côté échappement

ENGLISH

A For mounting standar  
 B For mounting Heavy Duty  
 C Without holes for front fixing  
 D With-holes for front fixing  
 E Intake side  
 F Exhaust side

DEUTSCH

A Für Lagerdeckel normal  
 B Für Lagerdeckel Hochleistung  
 C Ohne vorderen Befestigungslöcher  
 D Mit vorderen Befestigungslöcher  
 E Einlasseite  
 F Auslasseite

N° autotelaio N° de châssis Chassis no. Fahrgestell no.	3 → 1.029.000	8 → 1.230.001	13 → 1.840.000	18 → 880.001	23 → 1.375.000	28 → 1.410.280	33 → 645.001 ↔ 1.029.000	38 → 1.410.280 ↔ 1.820.000
	4 → 1.029.001	9 → 1.260.000	14 → 1.840.001	19 → 1.875.000	24 → 1.375.001	29 → 1.411.245	34 → 1.211.001 ↔ 1.230.000	39 → 1.411.246 ↔ 1.411.859
	5 → 1.211.000	10 → 1.260.001	15 → 862.000	20 → 1.875.001	25 → 1.820.000	30 → 1.411.246	35 → 862.001 ↔ 880.000	40 → 1.411.860 ↔ 1.820.000
	1 → 645.000	6 → 1.211.001	11 → 1.671.500	16 → 862.001	21 → 1.740.000	26 → 1.820.001	31 → 1.361.250	36 → 1.230.001 ↔ 1.260.000
	2 → 645.001	7 → 1.230.000	12 → 1.671.501	17 → 880.000	22 → 1.740.001	27 → 1.410.279	32 → 1.361.251	37 → 1.211.001 ↔ 1.260.000





# INCASTELLATURA MOTORE

Figura	Denominazione Description Benennung	Notes Notice Hinweise	N. d'Ordinazione N. de pièces Catalog No Bestell.-Nr.	Quantità	1300				1600				1750		2000				
					GIULIA T.I.	GIULIA SUPER	GIULIA SUPER 1,3	G.T. JUNIOR	G.T. JUNIOR 1,3	SPIDER JUNIOR	SPIDER JUNIOR 1,3	GIULIA SUPER 1,6	GIULIA SUPER 1,6	G.T. JUNIOR 1,6	SPIDER JUNIOR 1,6	BERLINA	G.T.V.	SPIDER V.	BERLINA
54	Cannotto		1315.10403	2	●	●	●	●	●	●	●	●	●	●	●	●	●	●	●
55	Anello tenuta		2340.35024	1	●	●	●	●	●	●	●	●	●	●	●	●	●	●	●
56	Anello tenuta		101.00.01.317.00	1	●	●	●	●	●	●	●	●	●	●	●	●	●	●	●
57	Cappuccio		105.00.01.570.01	4	●	●	●	●	●	●	●	●	●	●	●	●	●	●	●
58	Guarnizione		1306.12.028	4	●	●	●	●	●	●	●	●	●	●	●	●	●	●	●
59	Rondella		105.02.01.582.00	2	●	●	●	●	●	●	●	●	●	●	●	●	●	●	●
60	Guarnizione		2340.32243	5	●	●	●	●	●	●	●	●	●	●	●	●	●	●	●
61	Guarnizione		2340.32349	1		●	●	●	●	●	●	●	●	●	●	●	●	●	●
62	Guarnizione		2340.32336	1									●	●	●	●	●	●	●
63	Guarnizione		105.00.01.191.00	1	●	●	●	●	●	●	●	●	●	●	●	●	●	●	●
64	Guarnizione		2340.32231	1	●	●	●	●	●	●	●	●	●	●	●	●	●	●	●
65	Guarnizione		2340.32349	1		●	●	●	●	●	●	●	●	●	●	●	●	●	●
66	Coppa olio		105.00.01.021.06	1	●	●		●		●		●		●	●	●	●	●	●
			105.41.01.200.00	1			●		●		●		●	●	●	●	●	●	●
67	Guarnizione sottocoppa		105.00.01.210.03	1	●	●	●	●	●	●	●	●	●	●	●	●	●	●	●
68	Sotto coppa	{ prof. mm. 18 prof. mm. 28	105.00.01.211.03	1	●			●	●	●	●	●	●	●	●	●	●	●	●
			105.14.01.211.00	1	●	●	●	●	●	●	●	●	●	●	●	●	●	●	●
69	Salva coppa		105.26.01.871.02	1	●	●	●	●	●	●	●	●	●	●	●	●	●	●	●
70	Guarniz. coppa olio	{ per supp. senza prig. per supporto con prigionieri	105.00.01.205.06	1	●					●		●		●		●		●	
			105.00.01.205.07	1	●	●		●		●		●		●		●		●	
			116.00.01.205.00	1			●		●		●	●	●	●	●	●	●	●	●
71	Gommino tenuta		105.00.01.221.00	1	●	●	●	●	●	●	●	●	●	●	●	●	●	●	●
72	Tappo magnetico		106.00.01.238.00	1	●	●	●	●	●	●	●	●	●	●	●	●	●	●	●
73	Guarnizione		2340.32244	1	●			●		●		●		●		●		●	
			2340.32243	1		●	●		●		●		●		●		●		●
74	Serie guarnizioni per smerigliatura valvole		105.39.79.013.00	1	●														
			105.30.79.013.00	1		●	●	●	●	●	●	●	●	●	●	●	●	●	●
			105.26.79.013.00	1								●	●	●	●				
			105.48.79.013.00	1											●	●	●		
			105.12.79.013.00	1													●	●	●

Notes - Notice - Hinweise

FRANÇAIS

A Profondeur en mm.  
 B Pour support sans goujons  
 C Pour support avec goujons  
 D Pour de rodages des soupapes

ENGLISH

A Depth in mm.  
 B For mountig wit hout studs  
 C For mountig wit studs  
 D Valve Lapping parts

DEUTSCH

A Tiefe in mm.  
 B Für Lagerdechel ohne Bolzen  
 C Für Lagerdechel mit Bolzen  
 D Für Ventilschleifen

N° autotelaio N° ce châssis Chassis no. Fahrgestell no.	3 → 1.029.000	8 → 1.230.001	13 → 1.840.000	18 → 880.001	23 → 1.375.000	28 → 1.410.280	33 → 645.001 ↔ 1.029.000	38 → 1.410.280 ↔ 1.820.000
	4 → 1.029.001	9 → 1.260.000	14 → 1.840.001	19 → 1.875.000	24 → 1.375.001	29 → 1.411.245	34 → 1.211.001 ↔ 1.230.000	39 → 1.411.246 ↔ 1.411.859
	5 → 1.211.000	10 → 1.260.001	15 → 862.000	20 → 1.875.001	25 → 1.820.000	30 → 1.411.246	35 → 862.001 ↔ 880.000	40 → 1.411.860 ↔ 1.820.000
1 → 645.000	6 → 1.211.001	11 → 1.671.500	16 → 862.001	21 → 1.740.000	26 → 1.820.001	31 → 1.361.250	36 → 1.230.001 ↔ 1.260.000	
2 → 645.001	7 → 1.230.000	12 → 1.671.501	17 → 880.000	22 → 1.740.001	27 → 1.410.279	32 → 1.361.251	37 → 1.211.001 ↔ 1.260.000	





Figura	Denominazione Description Benennung	Notes Notice Hinweise	N. d'Ordinazione N. de pièces Catalog No Bestell.-Nr.	Quantità	1300						1600			1750		2000						
					GIULIA T.I.	GIULIA SUPER	GIULIA SUPER 1,3	G.T. JUNIOR	G.T. JUNIOR 1,3	SPIDER JUNIOR	SPIDER JUNIOR 1,3	GIULIA SUPER	GIULIA SUPER 1,6	G.T. JUNIOR 1,6	SPIDER JUNIOR 1,6	BERLINA	G.T.V.	SPIDER V.	BERLINA	G.T.V.	SPIDER V.	
75	Ser. fermi		105.26.79.014.00	1											●	●	●					
			105.39.79.014.00	1	●	●	●	●	●	●	●	●	●	●								
76	Serie guarniz. motore	A	con guarniz. del cop. senza fori ancor. ant.	105.00.79.011.00	1										●							
			105.06.79.010.00	1	●																	
			105.00.79.011.01	1													●					
			105.06.79.010.01	1	●																	
		B	con guarnizione del coperchio con fori ancoraggio anteriore	105.30.79.010.00	1		●		●		●											
			105.48.79.010.00	1											●	●	●					
			105.12.79.010.00	1															●	●	●	
			105.30.79.010.01	1																		
			115.03.79.010.00	1			●		●		●				●	●	●					
77	Guarniz. per compl. della serie		105.02.79.012.00	1										●								

Notes - Notice - Hinweise

FRANÇAIS

A Avec joint du couvercle sans trous d'encrage avant  
 B Avec joint de couvercle avec trous d'encrage avant

ENGLISH

A With cover gasket without holes for front fixing  
 B With cover gasket with holes for front fixing

DEUTSCH

A Mit Deckeldichtung ohne vorderen Befestigunglöcher  
 B Mit Deckeldichtung mit vorderen Befestigunglöcher

N.º autotelaio N.º de châssis Chassis no. Fahrgestell no.	3 → 1.029.000	8 → 1.230.001	13 → 1.840.000	18 → 880.001	23 → 1.375.000	28 → 1.410.280	33 → 645.001 ↔ 1.029.000	38 → 1.410.280 ↔ 1.820.000
1 → 645.000	4 → 1.029.001	9 → 1.260.000	14 → 1.840.001	19 → 1.875.000	24 → 1.375.001	29 → 1.411.245	34 → 1.211.001 ↔ 1.230.000	39 → 1.411.246 ↔ 1.411.859
2 → 345.001	5 → 1.211.000	10 → 1.260.001	15 → 862.000	20 → 1.875.001	25 → 1.820.000	30 → 1.411.246	35 → 862.001 ↔ 880.000	40 → 1.411.860 ↔ 1.820.000
6 → 1.211.001	7 → 1.230.000	11 → 1.671.500	16 → 862.001	21 → 1.740.000	26 → 1.820.001	31 → 1.361.250	36 → 1.230.001 ↔ 1.260.000	
		12 → 1.671.501	17 → 880.000	22 → 1.740.001	27 → 1.410.279	32 → 1.361.251	37 → 1.211.001 ↔ 1.260.000	



Scanned by Dahr





Figura	Denominazione Description Benennung	Notes Notice Hinweise	N. d'Ordinazione N. de pièces Catalog No Bestell.-Nr.	Quantità	1300				1600			1750		2000							
					GIULIA T.I.	GIULIA SUPER	GIULIA SUPER 1,3	G.T. JUNIOR	G.T. JUNIOR 1,3	SPIDER JUNIOR	SPIDER JUNIOR 1,3	GIULIA SUPER	GIULIA SUPER 1,6	G.T. JUNIOR 1,6	SPIDER JUNIOR 1,6	BERLINA	G.T.V.	SPIDER V.	BERLINA	G.T.V.	SPIDER V.
1	Confezione albero motore		105.00.02.063.00	1																	
			105.06.02.063.00	1	●	●	●	●	●	●	●										
			105.41.02.063.00/01	1										●	●	●					
			105.12.02.063.00	1														●	●	●	
2	Serie cuscinetti per albero motore	Normale 1ª magg. 2ª magg.	A 101.10.02.111.00/01	1	●	●	●	●	●	●	●	●	●	●	●	●	●	●	●		
			B 101.10.02.111.03/01	1	●	●	●	●	●	●	●	●	●	●	●	●	●	●	●	●	
			C 101.10.02.111.04/01	1	●	●	●	●	●	●	●	●	●	●	●	●	●	●	●	●	
3	Serie cuscinetti di biella	Fino al motore n.03734	Normale A 1315.16712	1	●	●	●	●	●	●	●	●	●	●	●	●	●	●	●		
			1ª magg. B 1315.16712/1	1	●	●	●	●	●	●	●	●	●	●	●	●	●	●	●	●	
			2ª magg. C 1315.16712/2	1	●	●	●	●	●	●	●	●	●	●	●	●	●	●	●	●	
			Dal motore n.03735	Normale A 105.00.02.203.00/01	1									●	●	●	●	●	●	●	●
		1ª magg. D B 105.00.02.301.01/01		1									●	●	●	●	●	●	●	●	
		2ª magg. C 105.00.02.203.02/01		1									●	●	●	●	●	●	●	●	
		Normale A 105.41.02.203.00/01		1													●	●	●	●	
		1ª magg. E B 105.41.02.203.01/01	1													●	●	●	●		
2ª magg. C 105.41.02.203.02/01	1													●	●	●	●				
4	Semicuscinetto di biella post. sup.	Boll. Rosso Boll. Bleu	F 105.12.02.232.02	1													●	●	●		
			G 105.12.02.232.00	1														●	●	●	
5	Semicuscinetto di biella post. inf.	Boll. Rosso Boll. Bleu	F 105.12.02.203.05	1													●	●	●		
			G 105.12.02.203.01	1														●	●	●	
6	Semicuscinetto di biella ant. centr.	Boll. Rosso Boll. Bleu	F 105.12.02.203.04	6													●	●	●		
			G 105.12.02.203.00	6														●	●	●	
7	Semicuscinetto di banco intermedio	Boll. Rosso Boll. Bleu	F 105.12.02.111.02	4													●	●	●		
			G 105.12.02.111.01	4														●	●	●	
8	Semic. di banco ant. centr. post.	Boll. Rosso Boll. Bleu	F 105.12.02.112.02	6													●	●	●		
			G 105.12.02.112.01	6														●	●	●	
9	Canna cilindro		1315.12017	4	●	●	●	●	●	●	●										
			105.00.01.101.00	4								●	●	●	●						
			105.48.01.101.01	4												●	●	●			
			105.12.01.101.00	4														●	●	●	

Notes - Notice - Hinweise

FRANÇAIS

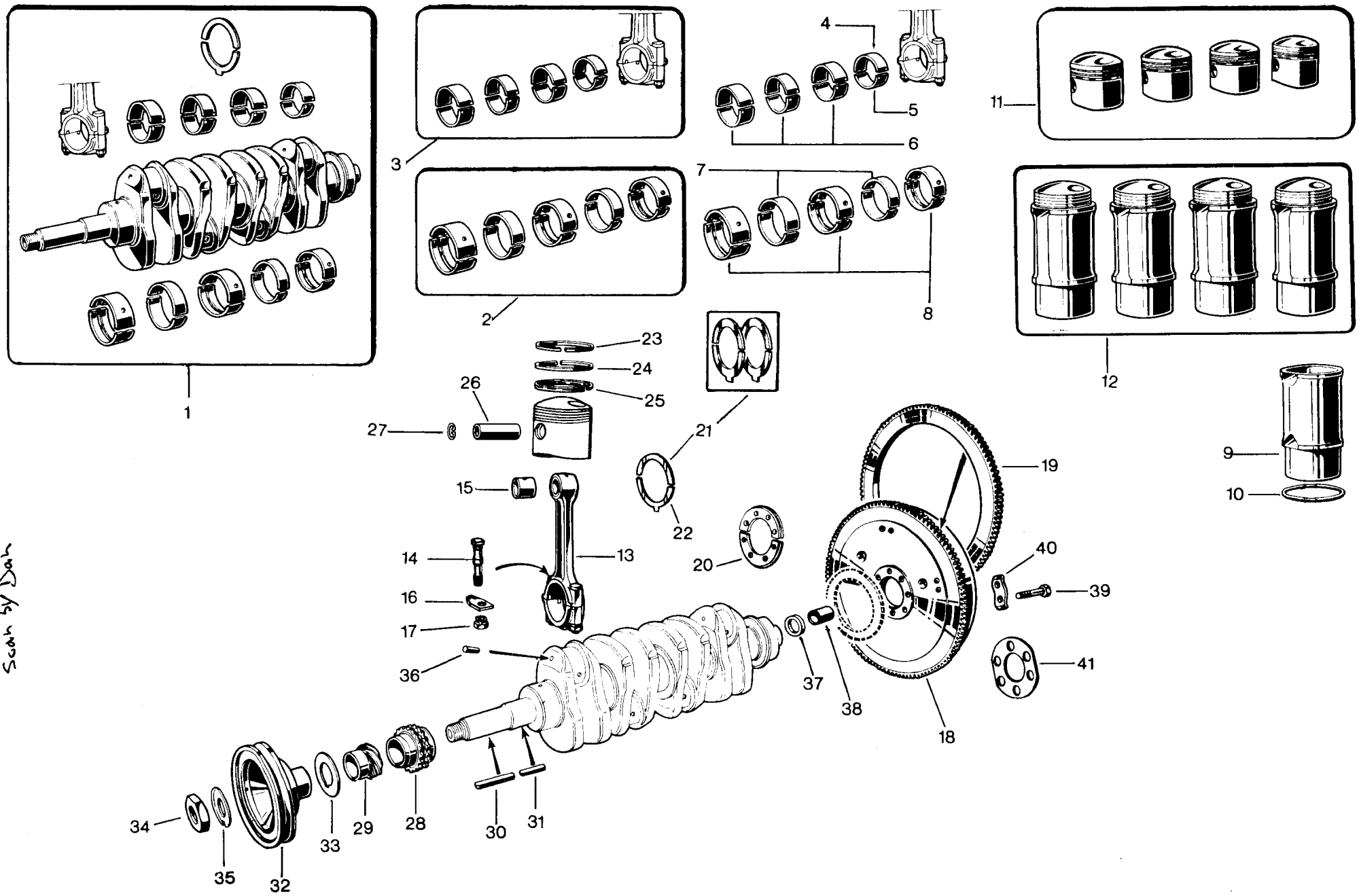
A Cote d'origine  
 B 1ère cote réparation  
 C 2ème cote réparation  
 D Jusqu'au moteur N. 03734  
 E Depuis 2le moteur N. 073735  
 F Repère rouge  
 G Repère bleu

ENGLISH

A Standard  
 B 1st oversize  
 C 2nd oversize  
 D Up to engine s no. 03734  
 E From engine s no. 03735  
 F Red mark  
 G Blue mark

DEUTSCH

A Normal  
 B 1. Über mass  
 C 2. Über mass  
 D Bis Motor-Nr. 03734  
 E Ab Motor-Nr. 03735  
 F Rote Marke  
 G Blaue Marke

N° autotelaio N° de châssis Chassis no. Fahrgestell no.	3 → 1.029.000	8 → 1.230.001	13 → 1.840.000	18 → 880.001	23 → 1.375.000	28 → 1.410.280	33 → 645.001 ↔ 1.029.000	38 → 1.410.280 ↔ 1.820.000
	4 → 1.029.001	9 → 1.260.000	14 → 1.840.001	19 → 1.875.000	24 → 1.375.001	29 → 1.411.245	34 → 1.211.001 ↔ 1.230.000	39 → 1.411.246 ↔ 1.411.859
	5 → 1.211.000	10 → 1.260.001	15 → 862.000	20 → 1.875.001	25 → 1.820.000	30 → 1.411.246	35 → 862.001 ↔ 880.000	40 → 1.411.860 ↔ 1.820.000
	1 → 645.000	6 → 1.211.001	11 → 1.671.500	16 → 862.001	21 → 1.740.000	26 → 1.820.001	31 → 1.361.250	36 → 1.230.001 ↔ 1.260.000
	2 → 645.001	7 → 1.230.000	12 → 1.671.501	17 → 880.000	22 → 1.740.001	27 → 1.410.279	32 → 1.361.251	37 → 1.211.001 ↔ 1.260.000





Figura	Denominazione Description Benennung	Notes Notice Hinweise	N. d'Ordinazione N. de pièces Catalog No Bestell.-Nr.	Quantità	1300				1600				1750			2000			
					GIULIA T.I.	GIULIA SUPER	GIULIA SUPER 1,3	G.T. JUNIOR	G.T. JUNIOR 1,3	SPIDER JUNIOR	SPIDER JUNIOR 1,3	GIULIA SUPER	GIULIA SUPER 1,6	G.T. JUNIOR 1,6	SPIDER JUNIOR 1,6	BERLINA	G.T.V.	SPIDER V.	BERLINA
10	Anello tenuta		1315.12407	4	●	●	●	●	●	●									
			101.10.01.102.00	4							●	●	●	●					
			105.41.01.102.00	4										●	●	●			
			105.12.01.102.00	4													●	●	●
11	Gruppo pistoni	rapp. di compress. 8,5 non cinturati	A 1315.18718/1	1	●			●											
			B 105.02.02.030.09/01	1							●								
		cinturati	C 105.08.02.030.00/01	1							●	●	●	●					
		rapp. di compress. 9	A 105.30.02.030.01/01	1	●	●	●	●	●	●	●								
			105.48.02.030.04/01	1										21	23	25			
			105.48.02.030.10/01	1										22	24	26			
			105.12.02.030.00/01	1													●	●	●
12	Gruppo canne-pistoni	rapp. di compress. 8,5 non cinturati	A 1315.18719/1	1	●			●											
			B 105.02.02.031.09/01	1							●								
		cinturati	C 105.08.02.031.01/01	1							●	●	●	●					
		rapp. di compress. 9	A 105.30.02.031.01/01	1	●	●	●	●	●	●	●								
			105.48.02.031.04/01	1										21	23	25			
			105.48.02.031.10/01	1										22	24	26			
			105.12.02.031.00/01	1													●	●	●
13	Biella		101.11.02.020.00	4	●	●	●	●	●	●									
			116.00.02.020.01	4							●	●	●	●					
			105.41.02.020.03	4										●	●	●			
			105.12.02.020.01	4													●	●	●
14	Vite fiss. cappelli di biella		1315.16003	8	●	●	●	●	●	●									
			105.00.02.204.00	2							●			●	●	●			
			116.00.02.204.00	8								●	●	●					
			116.08.02.204.00	8												●	●	●	
15	Boccola per biella		1315.16005	4	●	●	●	●	●	●									
			105.00.02.202.00	4							●	●	●	●	●	●	●	●	
16	Piastrina di sicurezza		1315.16018	8	●	●	●	●	●	●									
			105.00.02.206.00	8							●			●	●	●			

Notes - Notice - Hinweise

FRANÇAIS

A Rapport de compression  
B Ne armé pas  
C Armé

ENGLISH

A Compression ratio  
B Unbelted  
C Belted

DEUTSCH

A Verdichtungsverhältnis  
B Normalreifen  
C Stahlgürtelreifen

N° autotelaio N° de châssis Chassis no. Fahrgestell no.	3 → 1.029.000	8 → 1.230.001	13 → 1.840.000	18 → 880.001	23 → 1.375.000	28 → 1.410.280	33 → 645.001	38 → 1.410.280
	4 → 1.029.001	9 → 1.260.000	14 → 1.840.001	19 → 1.875.000	24 → 1.375.001	29 → 1.411.245	34 → 1.211.001	39 → 1.411.246
	5 → 1.211.000	10 → 1.260.001	15 → 862.000	20 → 1.875.001	25 → 1.820.000	30 → 1.411.246	35 → 862.001	40 → 1.411.860
	1 → 645.000	11 → 1.671.500	16 → 862.001	21 → 1.740.000	26 → 1.820.001	31 → 1.361.250	36 → 1.230.001	
	2 → 645.001	12 → 1.671.501	17 → 880.000	22 → 1.740.001	27 → 1.410.279	32 → 1.361.251	37 → 1.211.001	
								1.820.000
								1.411.859
								880.000
								1.260.000
								1.260.000





Figura	Denominazione Description Benennung	Notes Notice Hinweise	N. d'Ordinazione N. de pièces Catalog No Bestell.-Nr.	Quantità	1300				1600				1750		2000					
					GIULIA T.I.	GIULIA SUPER	GIULIA SUPER 1,3	G.T. JUNIOR	G.T. JUNIOR 1,3	SPIDER JUNIOR	SPIDER JUNIOR 1,3	GIULIA SUPER 1,6	GIULIA SUPER 1,6	G.T. JUNIOR 1,6	SPIDER JUNIOR 1,6	BERLINA	G.T.V.	SPIDER V.	BERLINA	G.T.V.
17	Dado fiss. cappelli di biella		1315.16004	8	●	●	●	●	●	●	●									
			105.00.02.205.00	8							●				●	●	●			
			116.08.02.205.00	8								●	●	●				●	●	●
18	Volano motore con corona		105.00.02.040.01	1								17								
			105.06.02.040.00	1	3			7		11										
			105.41.02.040.00	1	4	●	●	8	●	12	●	18	●	●	●	●	●			
			105.12.02.040.00	1														●	●	●
19	Corona dentata		105.00.02.401.00	1	3			7		11		17								
			105.41.02.401.00	1	4	●	●	8	●	12	●	18	●	●	●	●	●			
			116.00.02.401.01	1														●	●	●
20	Semianello	D	101.10.02.404.00	2	●							●								
			105.00.02.404.00	2	●	●	●	●	●	●	●	●	●	●	●	●	●	●	●	●
21	Semianello di spinta superiore	A	116.08.02.106.00/01	1	●	●	●	●	●	●	●	●	●	●	●	●	●	●	●	
			101.10.02.106.01	2	●	●	●	●	●	●	●	●	●	●	●	●	●	●	●	●
			101.10.02.106.02	2	●	●	●	●	●	●	●	●	●	●	●	●	●	●	●	●
22	Semianello di spinta inf.	B	101.10.02.107.01	2	●	●	●	●	●	●	●	●	●	●	●	●	●	●	●	
			101.10.02.107.02	2	●	●	●	●	●	●	●	●	●	●	●	●	●	●	●	●
23	Anello superiore	G	D	105.00.02.301.05	4							●								
				105.00.02.301.06	4									●						
			105.14.02.301.00	4										●						
			F	105.00.02.301.07	4									●	●	●	●			
		105.08.02.301.00		4									●	●	●	●				
		E	105.06.02.301.00	4	●			●												
			105.39.02.301.00	4	●	●	●	●	●	●	●									
		105.39.02.301.01	4	●	●	●	●	●	●	●										
105.41.02.301.01	4											●	●	●						
105.12.02.301.00	4															●	●	●		
24	Anello interm.	G	105.14.02.302.00	4								●								
			F	105.00.02.302.00	4								●	●	●	●				
				105.08.02.302.00	4									●	●	●	●			

Notes - Notice - Hinweise

FRANCAIS

A Cote d'origine - Jeu de pièces  
 B 1ère cote réparation  
 C 2ème cote réparation  
 D Epaisseur mm.  
 E Rapport de compression  
 F Pour piston armé  
 G Pour piston pas armé

ENGLISH

A Standard - Set.  
 B 1st oversize  
 C 2nd oversize  
 D mm. thick  
 E Compression ratio  
 F For piston belted  
 G For piston unbelted

DEUTSCH

A Normal - Serie  
 B 1. Über mass  
 C 2. Über mass  
 D mm. stark  
 E Für Verdichtungsverhältnis  
 F Für Kolben Stahgürtelreifen  
 G Für Kolben Normalreifen

N° autotelaio N° de châssis Chassis no. Fahrgestell no.	3 → 1.029.000	8 → 1.230.001	13 → 1.840.000	18 → 880.001	23 → 1.375.000	28 → 1.410.280	33 → 645.001	38 → 1.410.280
	4 → 1.029.001	9 → 1.260.000	14 → 1.840.001	19 → 1.875.000	24 → 1.375.001	29 → 1.411.245	34 → 1.211.001	39 → 1.411.246
	5 → 1.211.000	10 → 1.260.001	15 → 862.000	20 → 1.875.001	25 → 1.820.000	30 → 1.411.246	35 → 862.001	40 → 1.411.860
	1 → 645.000	11 → 1.671.500	16 → 862.001	21 → 1.740.000	26 → 1.820.001	31 → 1.361.250	36 → 1.230.001	
	2 → 645.001	12 → 1.671.501	17 → 880.000	22 → 1.740.001	27 → 1.410.279	32 → 1.361.251	37 → 1.211.001	

*Alfa Romeo*

Figura	Denominazione Description Benennung	Notes Notice Hinweise	N. d'Ordinazione N. de pièces Catalog No Bestell.-Nr.	Quantità	1300				1600				1750			2000				
					GIULIA T.I.	GIULIA SUPER	GIULIA SUPER 1,3	G.T. JUNIOR	G.T. JUNIOR 1,3	SPIDER JUNIOR	SPIDER JUNIOR 1,3	GIULIA SUPER	GIULIA SUPER 1,6	G.T. JUNIOR 1,6	SPIDER JUNIOR 1,6	BERLINA	G.T.V.	SPIDER V.	BERLINA	G.T.V.
24	Anello interm.	C	per rapp. compr. 8,5 Goetze	101.29.02.302.00	4	●			●											
			per rapporto compress. 9	Goetze	105.39.02.302.00	4	●	●	●	●	●	●								
				Borgo	105.39.02.302.01	4	●	●	●	●	●	●								
			Borgo	105.41.02.302.01	4									●	●	●				
			Goetze	105.41.02.302.02	4									●	●	●				
	Borgo	105.12.02.302.00	4													●	●	●		
25	Anello raschia olio	A	per pist. non cint. Borgo	105.14.02.304.00	4							●					●	●	●	
			per pist. cint.	Goetze	105.00.02.304.00	4							●	●	●	●				
		Borgo		105.08.02.304.00	4							●	●	●	●					
		Goetze	105.39.02.304.00	4	●	●	●	●	●	●										
		Borgo	105.39.02.304.01	4	●	●	●	●	●	●										
		Borgo	105.41.02.304.03	4									●	●	●					
		Goetze	105.48.02.304.00	4									●	●	●					
	Borgo	105.12.02.032.00	4													●	●	●		
26	Spinotto	C	per rapp. di compr. 8,5 g	1315.18001	4	●	●	●	●	●	●									
				105.08.02.306.00	4							●	●	●	●					
			105.41.02.306.01	4										●	●	●				
			105.12.02.306.00	4														●	●	●
27	Anello	C	per rapp. di compr. 8,5	1315.18011	8	●			●											
				105.39.02.307.00	8	●		●	●	●	●									
			per rapp. di compr. 9	105.00.02.307.00	8		●					●	●	●	●	●	●	●	●	
28	Pignone comando catena		1315.30039	1	●	●	●	●	●	●	●	●	●	●	●	●	●	●		
			116.08.03.107.00	1																
29	Ingranaggio		1315.32007	1	●	●	●	●	●	●	●	●	●	●	●	●	●	●		
30	Chiavetta		116.08.02.113.02	1	●	●	●	●	●	●	●	●	●	●	●	●	●	●		
31	Chiavetta		1315.14019	1	●	●	●	●	●	●	●	●	●	●	●	●	●	●		
32	Puleggia	D	per dinamo	105.00.02.102.03	1	●			●			●								
			per alternatore	E	105.14.02.102.00	1								●	●	●				
				105.48.02.102.00	1		●	●	●	●	●			●	●	●	●	●	●	

Notes - Notice - Hinweise

FRANÇAIS

A Pour piston pas armé  
 B Pour piston armé  
 C Rapport de compression  
 D Pour moteurs avec dynamo  
 E Pour moteurs avec alternateur

ENGLISH

A For piston unbelted  
 B For piston belted  
 C Compression ratio  
 D For engine with dynamo  
 E For engine with alternator

DEUTSCH

A Für Kolben normalreifen  
 B Für Kolben stahlgürtelreifen  
 C Verdichtungsverhältnis  
 D Für Lichtmaschine  
 E Für Drehstromgenerator

N° autotelaio N° de châssis Chassis no. Fahrgestell no.	3 → 1.029.000	8 → 1.230.001	13 → 1.840.000	18 → 880.001	23 → 1.375.000	28 → 1.410.280	33 → 645.001	38 → 1.410.280
	4 → 1.029.001	9 → 1.260.000	14 → 1.840.001	19 → 1.875.000	24 → 1.375.001	29 → 1.411.245	34 → 1.211.001	39 → 1.411.246
	5 → 1.211.000	10 → 1.260.001	15 → 862.000	20 → 1.875.001	25 → 1.820.000	30 → 1.411.246	35 → 862.001	40 → 1.411.860
1 → 645.000	6 → 1.211.001	11 → 1.671.500	16 → 862.001	21 → 1.740.000	26 → 1.820.001	31 → 1.361.250	36 → 1.230.001	
2 → 645.001	7 → 1.230.000	12 → 1.671.501	17 → 880.000	22 → 1.740.001	27 → 1.410.279	32 → 1.361.251	37 → 1.211.001	





Figura	Denominazione Description Benennung	Notes Notice Hinweise	N. d'Ordinazione N. de pièces Catalog No Bestell.-Nr.	Quantità	1300				1600				1750		2000				
					GIULIA T.I.	GIULIA SUPER	GIULIA SUPER 1,3	G.T. JUNIOR	G.T. JUNIOR 1,3	SPIDER JUNIOR	SPIDER JUNIOR 1,3	GIULIA SUPER	GIULIA SUPER 1,6	G.T. JUNIOR 1,6	SPIDER JUNIOR 1,6	BERLINA	G.T.V.	SPIDER V.	BERLINA
33	Paraolio		105.48.02.108.00	1	●	●	●	●	●	●	●	●	●	●	●	●	●	●	●
34	Dado		105.00.02.105.00	1	●	●	●	●	●	●	●	●	●	●	●	●	●	●	●
35	Rondella di sicurezza		105.00.02.104.00	1	●	●	●	●	●	●	●	●	●	●	●	●	●	●	●
36	Tappo		1306.14041	1	●	●	●	●	●	●	●	●	●	●	●	●	●	●	●
37	Anello di feltro		1315.14017	1	●			●		●			●	●	●				
38	Boccola { ∅ esterno mm. 20 ∅ esterno mm. 24	A	1315.14005	1	●			●		●			●	●	●				
			105.41.02.124.00	1	●	●	●	●	●	●	●	●	●	●	●	●	●	●	●
39	Vite fiss. volano		105.00.02.403.04	8	●	●	●	●	●	●	●	●	●	●	●				
			105.12.02.403.00	8														●	●
40	Piastrina di sicurezza		105.00.02.402.01	4	●	●	●	●	●	●	●	●	●	●	●				
41	Rondella		105.12.02.402.00	1													●	●	●

Notes - Notice - Hinweise

FRANÇAIS

A ∅ ext. mm.

ENGLISH

A mm. O.D.

DEUTSCH

A Aussen - ∅ mm.

N° autotelaio N° de châssis Chassis no. Fahrgestell no.	3 → 1.029.000	8 → 1.230.001	13 → 1.840.000	18 → 880.001	23 → 1.375.000	28 → 1.410.280	33 → 645.001 ↔ 1.029.000	38 → 1.410.280 ↔ 1.820.000
1 → 645.000	4 → 1.029.001	9 → 1.260.000	14 → 1.840.001	19 → 1.875.000	24 → 1.375.001	29 → 1.411.245	34 → 1.211.001 ↔ 1.230.000	39 → 1.411.246 ↔ 1.411.859
2 → 645.001	5 → 1.211.000	10 → 1.260.001	15 → 862.000	20 → 1.875.001	25 → 1.820.000	30 → 1.411.246	35 → 862.001 ↔ 880.000	40 → 1.411.860 ↔ 1.820.000
6 → 1.211.001	7 → 1.230.000	11 → 1.671.500	16 → 862.001	21 → 1.740.000	26 → 1.820.001	31 → 1.361.250	36 → 1.230.001 ↔ 1.260.000	
		12 → 1.671.501	17 → 880.000	22 → 1.740.001	27 → 1.410.279	32 → 1.361.251	37 → 1.211.001 ↔ 1.260.000	

*Alfa Romeo*

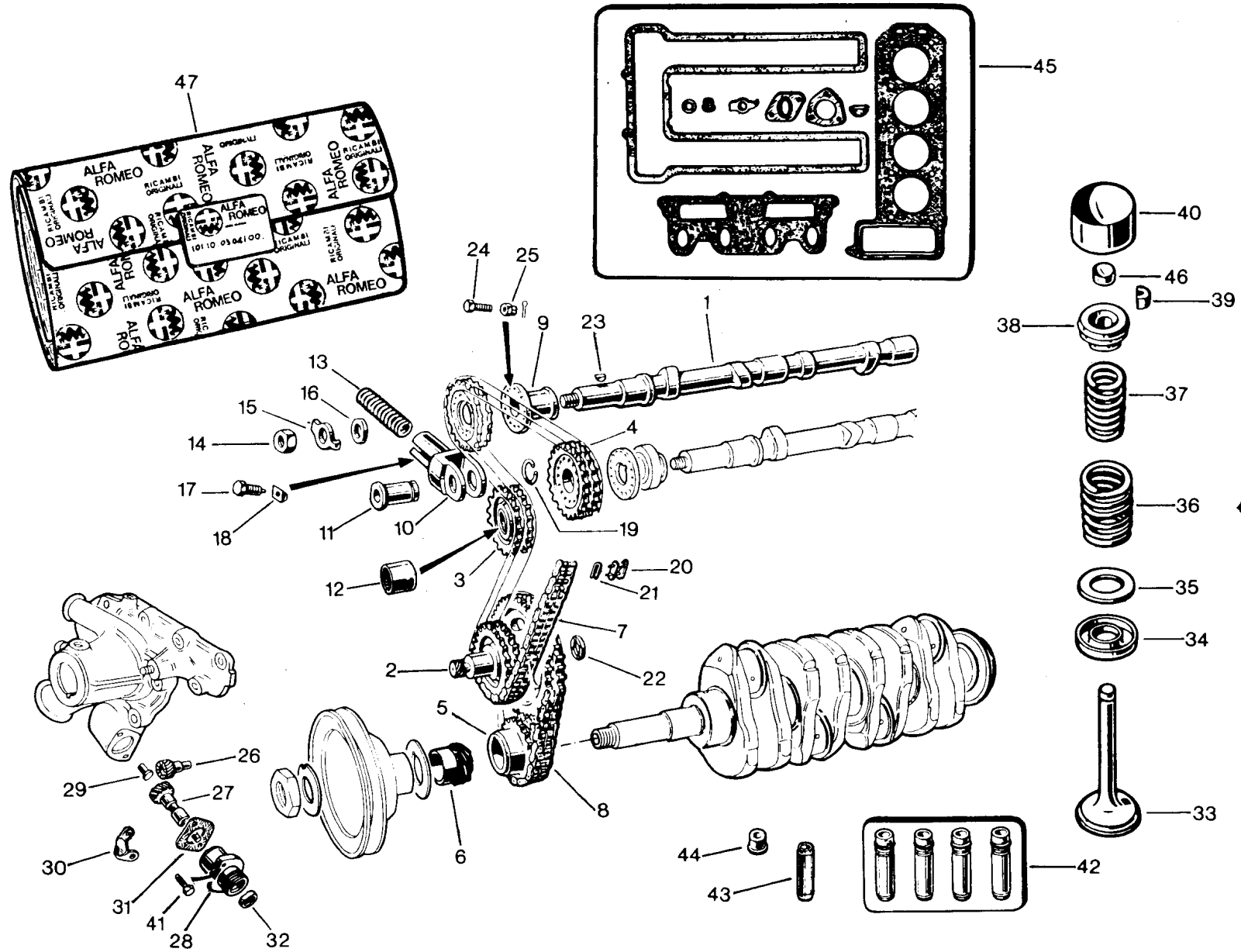



## **Catalogo Ricambi Alfa Romeo del 1974**

**Valido per Giulia TI, Giulia Super, GT Junior, Spider Junior nelle versioni 1300 e 1600 e ancora Berlina, GTV e Spider Veloce nelle versioni 1750 e 2000**

**Il catalogo è in italiano, francese, inglese e tedesco**

Il catalogo è in formato PDF, come questo file.

E' formato da 260 pagine, tutte stampabili.

E' richiesto un contributo pari a 15 euro con cui vi verrà spedito un CD imballato in modo adeguato.

La spedizione avverrà con posta prioritaria, se desiderate una spedizione raccomandata è necessario aggiungere 5 euro di spese postali.

Eventuali richieste devono essere inviate a [info@iw1axr.eu](mailto:info@iw1axr.eu)

Non dimenticatevi di specificare il manuale desiderato, il Vostro indirizzo e il sistema di pagamento che più gradite.

Grazie dell'attenzione, a presto.